

# P5000

## UV Emissions Analyser



### Overview

P5000 is an ultra-violet (UV), continuous emission monitoring analyser, designed for in-situ analysis of gas-phase emission components. Using absorption spectroscopy, P5000 stores and analyses the full UV spectrum and calculates the gas emission concentrations.

A typical system comprises an in-situ analyser and a Control Unit. P5000 uses the reflective beam principle to directly measure process gas as it enters the in-situ sample cell. Unlike higher maintenance extractive systems, Protea's patented, sintered metal technology removes the need for gas filtering or sample conditioning. The P5000 incorporates an auto verification unit which initiates zero and calibration checks ensuring compliance with international regulatory requirements. In addition the advanced diagnostics reduces operator interventions and maintenance requirements.

## Principles of Operation

**Analyser:** The P5000 analyser uses a single beam of UV light from a long-life deuterium lamp. The beam is split and directed into a folded beamcell assembly before returning to fall onto a 1024 bit diode receiver array. A narrow region of the spectrum is measured by each diode and the spectrum is logged as a vector intensity enabling gas concentrations to be calculated. Multiple gas-phase component concentrations can be monitored simultaneously. Uniquely, the operation, zeroing and calibration are "fully challenged" in that all operating modes use the same optical path and system components.

**Applications:** The P5000 analyser has been in service for over 15 years with continual product improvement to match ever-tightening legislative requirements. Over 100 P5000 units are in operation

worldwide – refer to our industry data sheets or visit [www.protea.ltd.uk](http://www.protea.ltd.uk) for typical applications and associated measurement ranges.

## Optional Components

Optional accessories are available to extend the analyser's capability in cases of extreme process or ambient variations. Typical examples would be a probe heater to ensure the in-situ gas cell operates above process gas dew point, a gas flow bypass for high thermal stress applications and a head cooler for operation in high ambient temperature conditions. For further details of these and many other accessories are available at [www.protea.ltd.uk](http://www.protea.ltd.uk) or on the accessories data sheet.

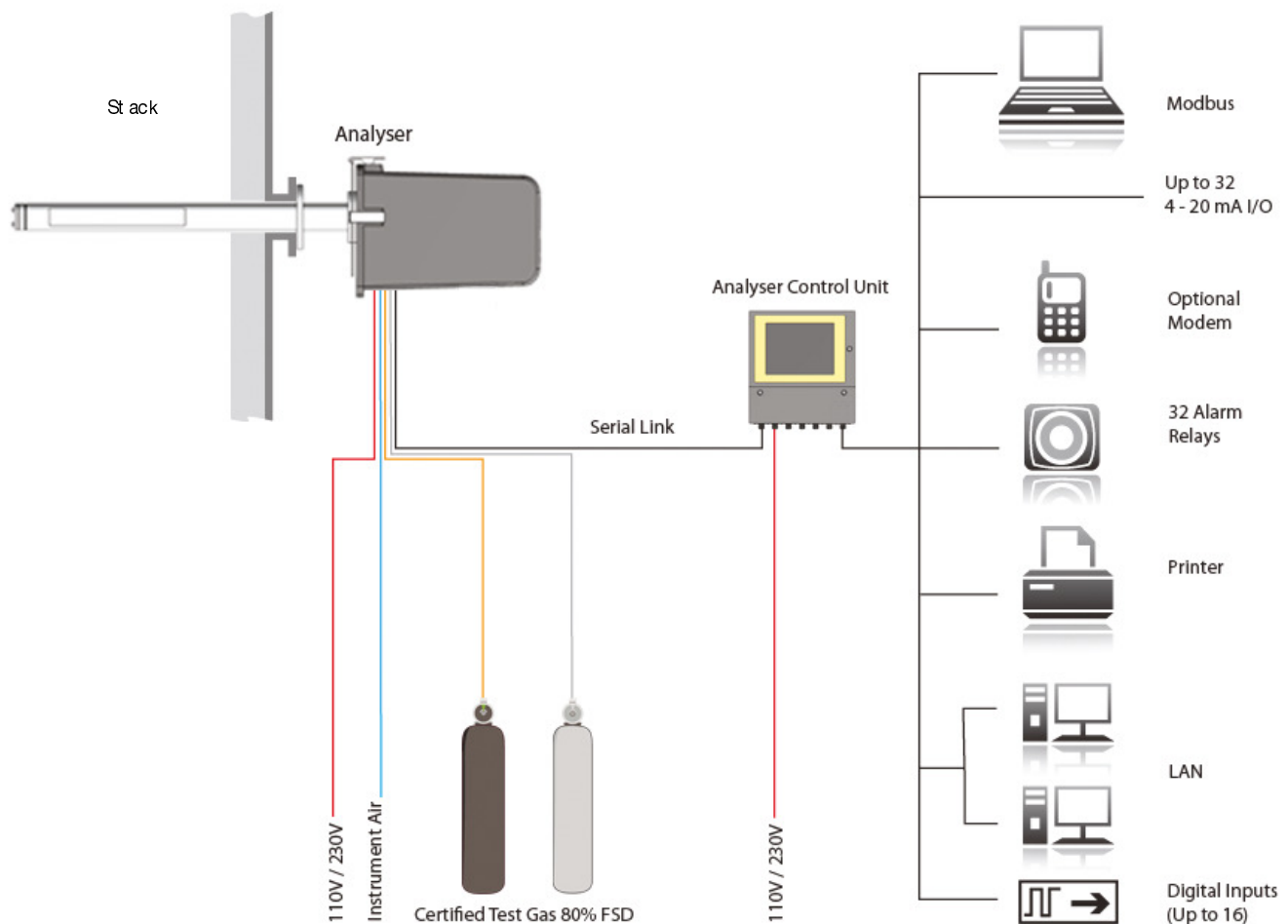

Features	Benefits
Multi-component gas analysis D	Each P5000 can monitor multiple gas concentrations.
Direct in-situ measurements	No requirement for high cost, high maintenance sample handling system or sample conditioning.
Automatic signal verification and recalibration	No operator intervention during routine use.
Oxygen or CO <sub>2</sub> measurement normalisation	Report measurement corrected to normalised O <sub>2</sub> or CO reference conditions
Flange mounted analyser	Reduced cost and simple of installation
Low maintenance	Reduced cost of through life ownership

### Monitoring Range

<b>Gases measured:</b>	Series of gas concentrations as determined by the application		
<b>Ranges (minimum):</b>			
<b>NO</b>	0-20ppm / 26mg/Nm <sup>3</sup>	<b>Cl<sub>2</sub></b>	0-20ppm / 26mg/Nm <sup>3</sup>
<b>NO<sub>2</sub></b>	0-20ppm / 41mg/Nm <sup>3</sup>	<b>O<sub>3</sub></b>	0-1ppm / 2mg/Nm <sup>3</sup>
<b>SO<sub>2</sub></b>	0-20ppm / 60mg/Nm <sup>3</sup>	<b>H<sub>2</sub>S</b>	0-20ppm / 30mg/Nm <sup>3</sup>

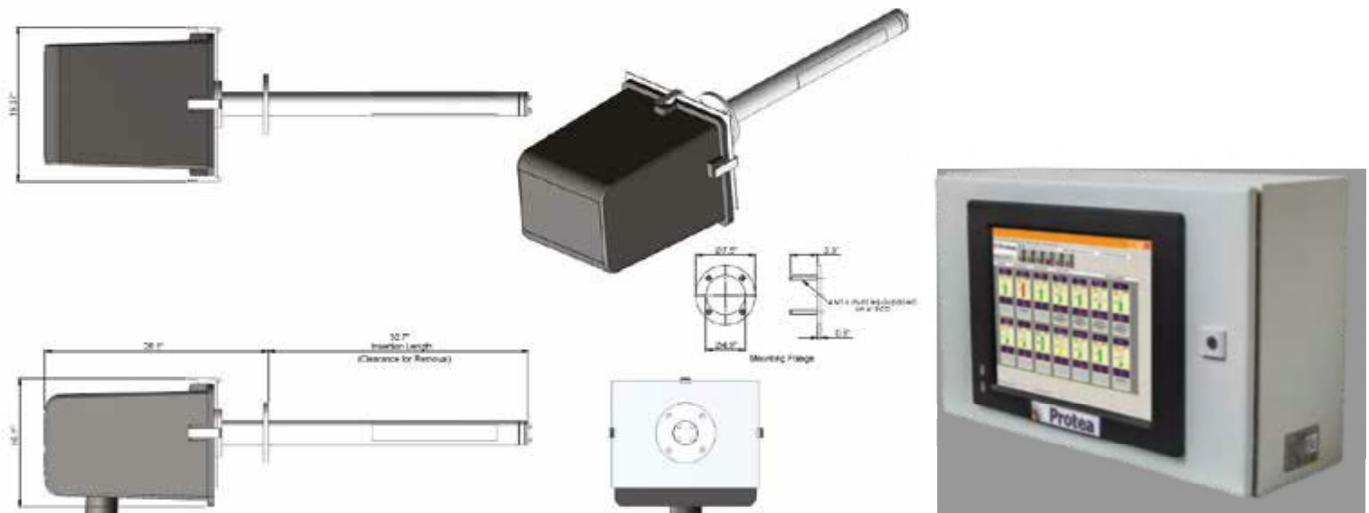

### Control Unit Options

The P-PC&S-PC data logging and control system can be either supplied as software only or installed in an IP65 control unit. The system is capable of controlling up to six, widely dispersed, Protea analysers of any design. The P-PC&S-PC series is also designed to accept signal I/O from other instruments in the process to provide

a single CEMS data hub. The P-PC&S-PC system displays gas concentrations and third party analyser I/O along with information on sample conditions, diagnostic data and trends. The information can also be made available to external systems in a variety of industry standard data protocols.

## Specifications & Installation

<b>Principle of operation:</b>	Ultra-violet absorption full spectrum method.
<b>Spectral range:</b>	180nm to 400nm.
<b>Ultra-violet source:</b>	Extended life deuterium lamp (typically 7000 hrs).
<b>Ultra-violet detector:</b>	Miniature 1024 bit photo diode array.
<b>Sample path length:</b>	1 metre. (Other lengths on application).
<b>Cross-sensitivity:</b>	Minimal due to full spectrum principle and advanced algorithms in the processor software.
<b>Pressure compensation:</b>	To allow for atmospheric/stack pressure variation.
<b>Accuracy:</b>	Typically $\pm 2\%$ of full scale concentration but dependent on application.
<b>Response time:</b>	Application dependent but typically 120 seconds to T90.
<b>Calibration requirements:</b>	Supplied pre-calibrated. Short term drift of less than the quoted accuracy is removed by zero calibration, carried out automatically, typically every 24 hours depending on application.
<b>Enclosure:</b>	Aluminium alloy casting with high protection finish, sealed to IP65 \NEMA 4X. Outer GRP weather protection.
<b>Operating environment</b>	-20°C to +45°C (-4°F to 113°F). Ducted air provision for extreme temperatures. Sample temperatures up to 400°C (750°F). (higher temperature on application).
<b>Materials in contact with sample:</b>	Calcium fluoride, glass, 316 stainless steel, graphite and fused silica.
<b>Services required:</b>	90-250V 80VA required for lamp PSU, head cooler fan (application dependent) and electronics. Instrument air for the analyser void purge, autozero and sample cell protection, controlled by the P 5000. Pressure 2.5-3 barg; flow rate 1 litre/min constant, regulator takes up to 10 bar but set to 2 barg to give correct flows as Autozero unit flow is pre-set for intake of 2 bar.
<b>Mounting flange:</b>	3" 150lb (note this is a special flange part number 4-1114).
<b>Weight:</b>	35kg (77.2lb)
<b>Dimensions:</b>	1544mm(60.78") x 492mm(19.37") x 410mm(16.14").

## Approvals

Continuous Emissions Monitoring C  
EM- US EPA 40 CFR part 60 & 75

The P5000 system is designed to meet the requirements of both customers and environmental authorities worldwide. The system enables rapid upgrades with regard to measuring range, presentation and reporting format, thus ensuring compliance with reporting criteria such as US EPA 40 CFR part 60 & 75 legislation. The system calculates errors due to drift in Zero & Span Calibration before correction.



This Datasheet is a guide to the product and Protea Ltd reserves the right to modify the product without notification.