



Measurement parameter

- Methane
- Carbon Dioxide
- Oxygen
- Hydrogen Sulfide
- Hydrogen
- Higher Hydrocarbons (C₂₊)

Applications

- Biogas Systems
- Sewage Treatment
- Landfill Sites
- Glass/Ceramics
- Chemical, Oil & Gas
- Energy Supply
- Energy Production
- Environmental Monitoring

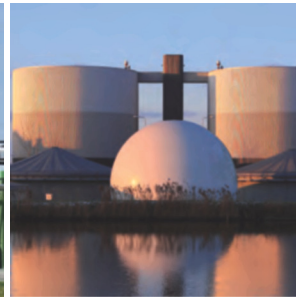

INCA

Gas analysis system for the
bio- and natural gas industries

INCA – design, measuring components, and method of operation

Modular design

INCA (cover picture) is a modular freely user configurable measurement device for multi-component gas analysis in the bio and natural gas industries. The INCA concept is designed to provide an analysis system custom made for a specific application using standard modules for sample gas supply, sample gas processing, sensor control and data processing. This approach guarantees the best possible analysis results, optimised cost structure in production and operation, short delivery times and facilitates retrofitting and/or replacement of components in the future. Only the series INCA1000 units have fixed configuration for use in pre-determined applications, e.g. Natural Gas.

The gas analysis measurement technology (figure 4) is designed as an independent unit in which all components such as sensors, pumps, valves and more, are connected to the control system via an internal device bus. The installation of sensors (sensor modules) is determined by the customer's specific application. This measurement unit can be configured as a complete system in an enclosure for operation in indoor, outdoor or explosion-proof areas as well as with or without a sample gas cooler or multiple stream switching options (figure 2).

INCA1000	Compact device configured for a pre-defined application
INCA2000	In planning stage for future release
INCA3000	Use with dry gases and indoor locations with or without sample stream switching
INCA4000	Use with saturated gases and indoor locations with or without sample stream switching
INCA5000	Use with dry gases and outdoor locations with or without sample stream switching (formerly named OUTDOOR INCA)
INCA6000	Use with saturated gases and outdoor locations with or without sample stream switching (formerly named OUTDOOR INCA)
INCA7000	In planning stage for future release
INCA8000	Like INCA3000, but for use in hazardous areas

Figure 1: INCA series

The modular concept results in a full range of different INCA units all designed for special applications (Figure 1).

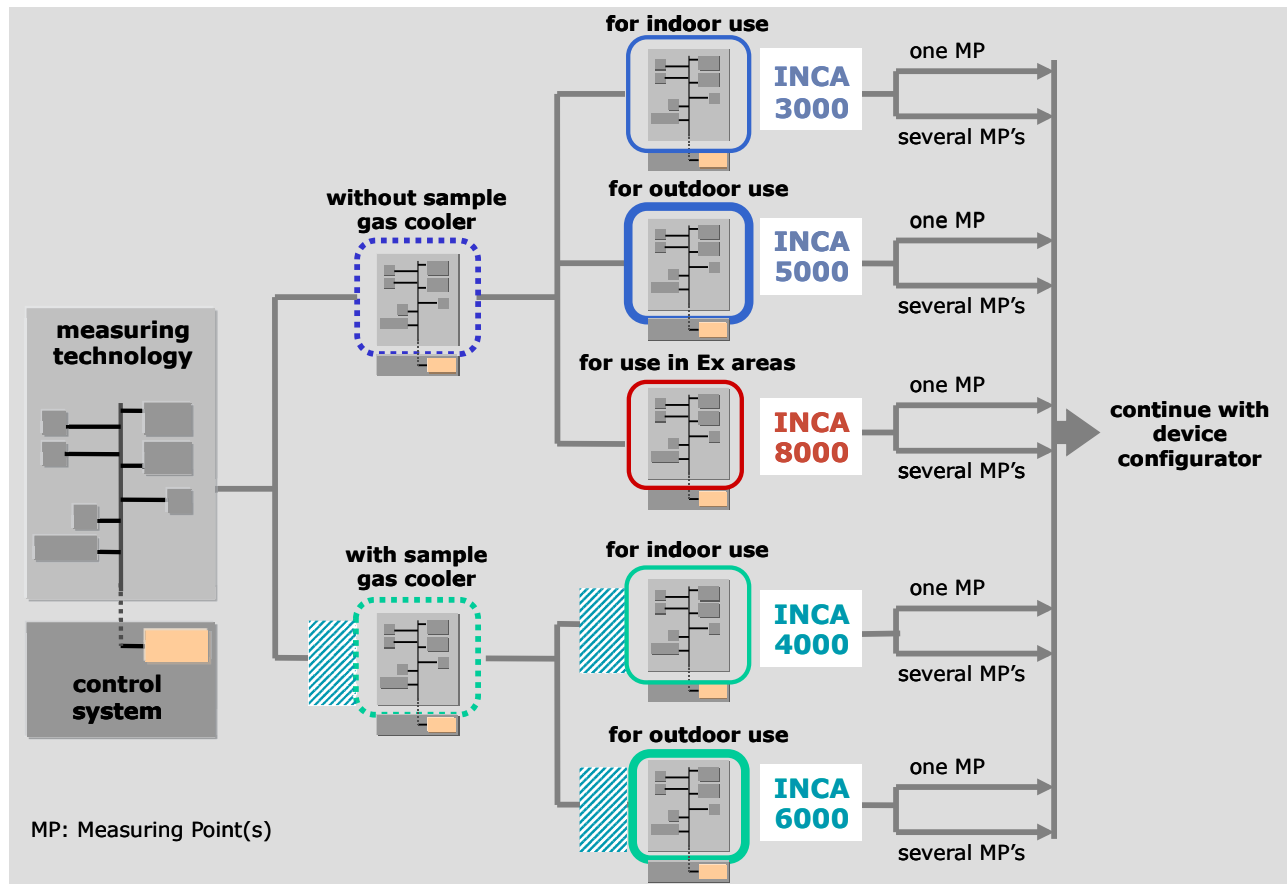

Figure 2: Schematic drawing of INCA models (INCA 1000 not shown)

T087	T100	T137	T301
CH ₄ 0–5 Vol.-% CO ₂ 0–100 Vol.-%	CH ₄ 0–100 Vol.-% CO ₂ 0–100 Vol.-% H ₂ S 0–10000 ppm O ₂ 0–25 Vol.-%	CH ₄ 0–100 Vol.-% CO ₂ 0–100 Vol.-% H ₂ S 0–100 ppm O ₂ 0–25 Vol.-% H ₂ 0–4000 ppm	CH ₄ 80–100 Vol.-% C ₂ + 0–15 Vol.-%
lean gas	biogas	biomethane	natural gas

Figure 3: Different examples for available sensor systems

Sensor types (T-Numbers)

The INCA sensors also have a modular design. They allow for determining the concentration of gaseous components: CH₄, CO₂, O₂, H₂S and H₂ as well as the gas density, from which characteristic values such as wobbe index, heating value, calorific value, specific gravity and others can be calculated.

In one sensor module, several sensors can be combined, which is used to specify preferred assembly variants (combination of gas components and measuring ranges). These sensor types are designated as T-numbers; they are designed for specific applications such as the analysis of biogas or natural gas, see Figure 3.

For sensor details please refer to the following page.

Modes of operation

As per function, INCA provides different modes of operation. The reasons for this are:

- Purging the electrochemical detectors with air to increase their service life
- Sample stream switching to several measuring points
- Protection of moving parts, e.g. pumps.

Continuous (online) operation

This mode of operation is used to determine CH₄, C₂₊, CO and CO₂ by using NDIR as well as O₂ by paramagnetic or electrochemical detector without any multi stream switching. In view of the sensors used in this mode an intermediate purge process is not required and this allows for continuous online operation.

Quasi-continuous (cycled) operation

Online operation as described above, but with a cycled measurement of approximately 15 minutes because of the sensor air purge that is used in between cycles to condition them. Used to determine H₂S and H₂ with electrochemical sensors or in general to preserve the working life of parts like the pumps.

For particularly critical measurements (H₂S) the patented Pulse procedure is also used which further increases operating time, measuring range and measuring accuracy of the (EC) electro chemical sensors.

Operation with measuring point switching

Sequential switching of the measurement technology to different sample gas flows e.g. in fermenter groups in biogas plants with several outputs or alarm warning devices.

Quasi-continuous operation

Measurement of several sample gas flows like above, but with a "preferred" process stream. A changeover to other streams can be activated externally (via Profibus) but is only done if irregularities in the process stream occur and needs to be verified as well as for control purposes.

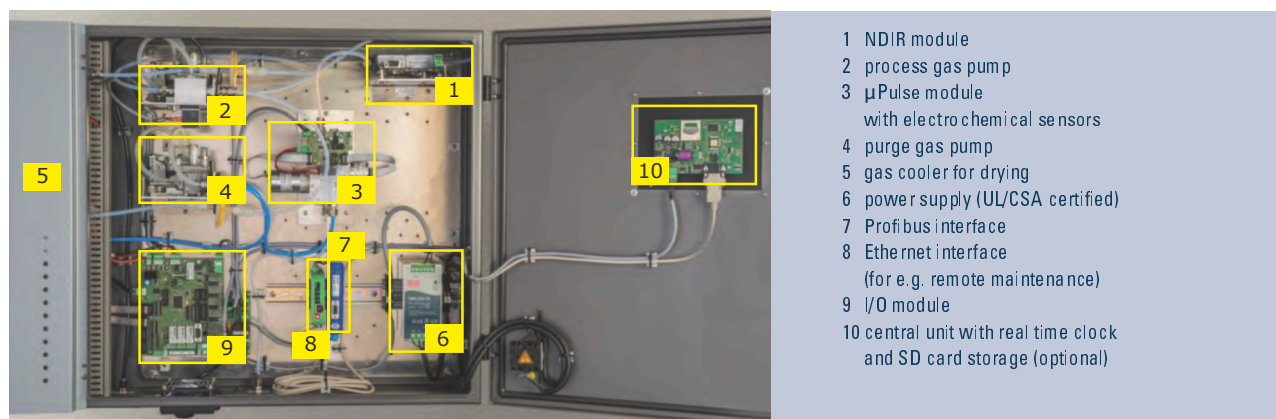

Figure 4: INCA-Main components

INCA – Detectors and sensors

Modular designed sensors

INCA detectors are the actual component-selective receivers with light source (in optical procedures), measurement chamber, filter and sensitive element.

INCA sensors are modules consisting of one or several detectors as well as electronics and memory storage for calibration data.

The sensor modules are designed and pre-calibrated for certain components and measuring ranges or combinations thereof. Integrating them into an INCA device only requires (apart from the mechanical assembly) to connect the module via a plug through a device bus (Figure 7) into the control system. This simple procedure is very useful for retrofitting, but also in case of a sensor change due to age or wear. For INCA, sensors with different physical or chemical detection procedures are available, see Figure 5 and associated text box.

Multipoint calibration of the sensors

Calibrating means the determination and documentation of systematic deviations of a measurement device from a “correct” value under given set of known conditions. For gas analysis devices, calibration gases are used for this purpose and the concentration data is usually certified by the gas supplier.

INCA sensors are always calibrated prior to delivery and the results are saved directly into the sensor module as a calibration curve. By including several measuring points over the measuring range, the data from these calibration curves is precisely controlled which facilitates subsequent user calibrations. For this, INCA offers simple and cost-efficient post calibration routines just with ambient air

- for CH₄, C₂H₂, H₂S and H₂: use of zero point
- for O₂: use of span.

The calibration gases required for INCA operation are usually provided by the user.

Measuring principle	Determinable gas components or gas properties
NDIR	CH ₄ , CO ₂ , CO, C ₂ H ₂
Electrochemical cell	O ₂ , H ₂ S, H ₂
Paramagnetic	O ₂
Acoustic	Specific Gravity (Density)

Figure 5: INCA measuring principle

NDIR sensors

The NDIR (non-dispersive infrared) technology uses the absorption properties of gases for light radiation in the infrared wavelength. Suitable filters select a specific wavelength from a broad spectrum light source that shows typical absorption behavior for the gas in question. This radiation passes a measurement cell filled with sample gas. The IR attenuation occurring during this process is proportional to the gas concentration. Thermal detectors (thermopiles) are used for signal measurement.

Electro-chemical sensors

Many gases react to other substances under specific conditions. If the reaction causes the release of electrons and thus a measurable current, the corresponding arrangement is called an electro-chemical cell. It consists of at least two catalytically acting electrodes connecting in an electrically conductive medium (electrolyte) and a circuit. At the junction of the electrode, gas and electrolyte, a current generating reaction occurs where the amperage shows the degree of the gas concentration. Note: Due to process conditions, electro-chemical sensors have a limited service life.

Paramagnetic sensors

Unlike most gases, oxygen is paramagnetic and thus attracted by a magnetic field. The resulting force from placing oxygen in a magnetic field serves to analyse the oxygen concentration in gases. This force is measured and registered, by e.g. generation of a rotary movement and converted into a signal proportional to the oxygen concentration.

Acoustic sensors (for density measurement)

The acoustic density measurement uses the impact of the sample gas on the oscillation amplitude of an induced sound wave. The sound amplitude detected by the pressure transducer depends directly on the density of the sample gas. A reference chamber filled with ambient air also increases measurement accuracy under all conditions.

INCA – Control and operation

Control system (real time operating system)

The control system is based on an embedded real time operating system. In terms of communication, all components are connected in the master-slave principle to the internal device bus which also controls the power supply (Figure 6). The fan control ensures that the analysis system is only supplied with power if the fan is running. The communication module offers the future-proof ability to implement not only a RS232 interface but also Ethernet networks and USB interfaces as well. Another advantage of the bus concept lies in the fact that replacement or installation only requires a plugin bus connection to be established.

Settings with INCACtrl

For all types of settings and for alarm analysis the PC software INCA ctrl (Windows) is used on an external computer or via TCP/IP.

INCACtrl allows for:

- setting calibration, purge and measurement cycles
- specification of operating time and calibration data
- parameterisation of analogue outputs
- reading and display of all measurement data

For remote internet based maintenance assistance access via INCACtrl is possible e.g. for queries of status messages.

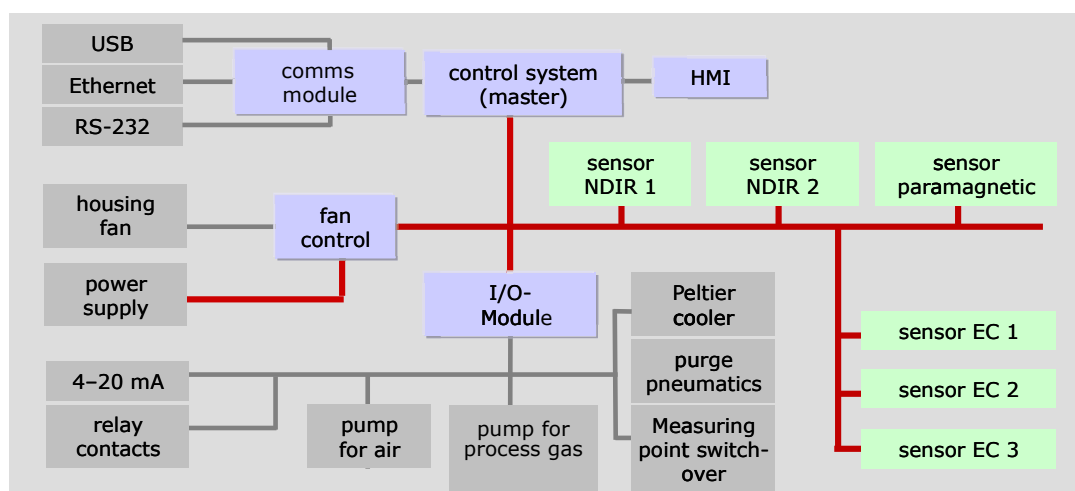

Figure 6: INCA components on the device bus

Operation

The operator panel is attached as one unit with the control system on or in the front of the enclosure. Operation is done via a membrane keyboard deliberately designed to be simple, user-friendly and always intuitive.

By consolidating basic program functions INCA can also be used safely by less experienced persons.

Figure 7 shows the operating elements (1–3 and 5) as well as the universal LC Display (4), which can be switched to show different values.

Different language versions (german, english, italian and spanish) are available. The operating system can be password protected against unauthorised access.

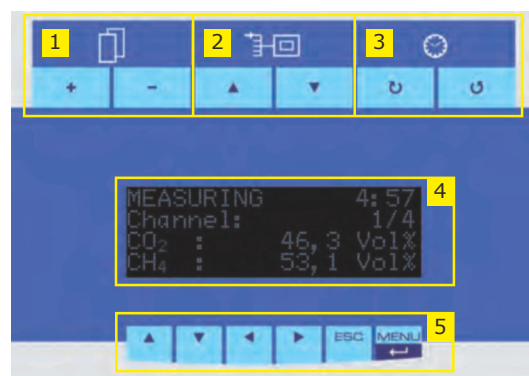

- 1 Display of current or saved sensor measured values
- 2 Display of the current measurement channel
- 3 Display of saved measured values (the last 10 values)
- 4 Display of status and channel as well as optional measured values such as temperature or pressure
- 5 Navigating the menu structure

Figure 7: Control panel and display

INCA – Technical data

	INCA1000	INCA3000	INCA5000	INCA4000	INCA6000	INCA8000
Weight [kg]	10	21	72	29	80	70
Dimensions (WxHxD) [cm]	48x33x25	68x65x25	120x110x44	80x65x25	120x110x44	60x48x34
Degree of protection	IP40	IP43	IP54	IP20	IP54	IP54 ¹⁾
Setup site	inside		outside	inside	outside	inside
Operating temperature	5° - 45°C		-20° - 45°C	5° - 45°C	-20° - 45°C	5° - 45°C
Sample gas cooler						
Condensate pump	Hose or jet pump ²⁾					
Inlets of process gas	1 - 2 ²⁾	1 - 4 ²⁾		1 - 10 ²⁾		1 - 2 ²⁾
Inlets of calibration gas	1 - 2 ²⁾			1		1 - 2 ²⁾
Inlets purging gas (air)	1					
Flame barrier	Ex G IIC					
Power supply	100 - 240 VAC, 50/60 Hz					
Max. power consumption	80 VA	100 VA	1500 VA	250 VA	1500 VA	100 VA
Storage temperature	-20° - 60°C					
CSA approval (optional)						
Ex approval						
Interfaces ²⁾	4-20 mA, RS-232, relay contacts, Ethernet (TCP/IP), Profibus-DP, Modbus-TCP, Modbus-RTU, Profinet					

Measurement components ³⁾			
Gas component	Measuring range	Measuring accuracy	Measuring principle
CH ₄	0 - 100 vol%	± 1% FS ⁴⁾ (± 1 vol%)	NDIR
CH ₄	0 - 5 vol%	± 3% FS ⁴⁾ (± 0,15 vol%)	NDIR
CH ₄	0 - 1 vol%	± 5% FS ⁴⁾ (± 0,05 vol%)	NDIR
CO ₂	0 - 100 vol%	± 1% FS ⁴⁾ (± 1 vol%)	NDIR
CO ₂	0 - 10 vol%	± 1,5% FS ⁴⁾ (± 0,15 vol%)	NDIR
C ₂₊	0 - 20 vol%	± 2,5% FS ⁴⁾ (± 0,50 vol%)	NDIR
H ₂ S	0 - 50.000 ppm (P ulse)	500 ppm: ± 30 ppm >500 ppm: ± 15% v. MV ⁵⁾	EC
H ₂ S	0 - 10.000 ppm (P ulse)	25 ppm: ± 3 ppm > 25 ppm: ± 15% v. MV ⁵⁾	EC
H ₂ S	0 - 10.000 ppm	± 3% FS ⁴⁾	EC
H ₂ S	0 - 2.000 ppm	1000 ppm: ± 30 ppm >1000 ppm: ± 3% v. MV ⁵⁾	
H ₂ S	0 - 100 ppm	± 3 ppm	EC
H ₂ S	0 - 50 ppm	± 1,5 ppm	EC
H ₂	0 - 4.000 ppm	± 5% FS ⁴⁾	EC
O ₂	0 - 25 vol%	± 0,1 vol% at zero point ± 0,1 vol% per 10°C ± 3% v. MV ⁵⁾	EC, paramagnetic
Relative density	0,2 - 2,2	± 1% FS ⁴⁾	acoustic
Relative density	0,5 - 0,8	± 3% FS ⁴⁾	calculated ⁶⁾
Heating value	8 - 11,5 kWh/m	± 1,5% FS ⁴⁾	calculated ⁶⁾
Wobbe index	10 - 14,3 kWh/m	± 2% FS ⁴⁾	calculated ⁶⁾

Figure 8: Technical data INCA

¹⁾ not valid for 19" control unit (rack mounted)

²⁾ depending on version

³⁾ others upon request

⁴⁾ "FS": (Full Scale) - of measuring range end value

⁵⁾ "MV": (Measured Value) - of measured value

⁶⁾ from measured gas components

INCA – Application

Versatile applications

Devices and systems for gas analysis are required in many parts of the process and gas industry. A special application is the determination of the composition of combustible gases as required in the fields of natural gas, biogas, biomethane, liquid gas, blast furnace gas, lean gas, landfill gas and others. For such applications, INCA is particularly suitable. This does not mean that INCA cannot be used for other applications as well, provided that the task matches the gas components that INCA can detect (CH₄, C₂, CO, CO₂, O₂, H₂S, H₂) and the measuring range required.

INCA in a biogas plant

The main application for INCA is to monitor the generation and processing of biogas. INCA provides a solution to the many different measurement tasks in a biogas plant (figure 9 to 11), thanks to its flexible design, usually with just one or two devices.

Today, UNION Instruments is one of the most successful suppliers of analysis technology in the biogas industry with many units in use in the worldwide market.

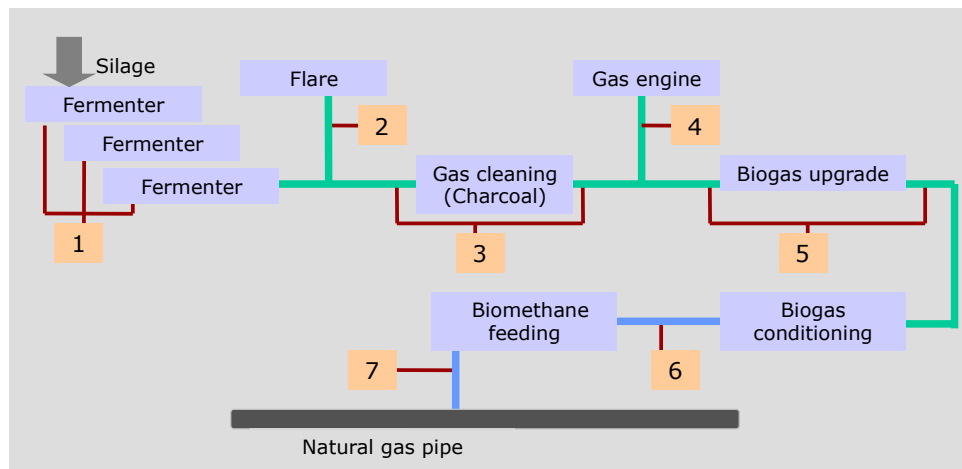

Figure 9: Use of INCA in a biogas plant



Figure 10: INCA installation

Measuring point	Position and application	Special suitability of INCA
1	At the fermenters, the composition of the saturated raw biogas is determined in different spots. This provides important information about how the process flows.	Robust stainless steel valves controlled by compressed air and a sample gas cooler with vacuum drainage allow direct sampling of the gases from the fermenters. This drainage keeps the lines clean and free from condensate.
2	At the inlet to the flare, the frequently fluctuating gas composition is determined at different locations. This provides important information about how the process runs.	The upstream sample gas cooler ensures reliable analysis of the condensate laden (saturated) gas.
3	Upstream and downstream of the gas cleaning (removal of H ₂ S), the gas composition is determined and thus function and/or saturation of the activated carbon filter are monitored.	The patented μ Pulse function allows for precise determination of H ₂ S upstream and downstream the gas cleaning (with measuring point changeover) despite the high difference in concentration.
4	A gas engine needs the monitoring of the gas quality to ensure the suitability of the gases before combustion.	The CH ₄ determination ensures reliable start and operation of the gas engine. The H ₂ S determination ensures optimal protection for gas engine and its exhaust system.
5	Upstream and downstream the biogas processing, the gas composition is determined. This monitors the biogas optimisation during a critical phase.	The flexible IR measuring ranges allow adjustment of the device optimally to the different gas source (raw biogas, biomethane, off-gas) as well as to the requirements of the different processing procedures (diaphragm technology, water scrubber, amine scrubber or others).
6	In the conditioning unit the biogas is monitored for dryness, pressure and heating value to ensure that it meets the specifications required for feeding it into a natural gas network.	The selectivity of the IR measurement technology allows for continuous measurement of both methane and propane in conditioned bio natural gas.
7	At the supply point into the natural gas network the biogas properties can be checked for quality one last time.	The ATEX-approved version for use in potentially explosive atmospheres can measure all relevant parameters in the gas supply system.

Figure 11: INCA performance in a biogas plant



About UNION Instruments

UNION Instruments GmbH, founded in 1919, is a specialized supplier of measuring instruments in the areas of calorimetry and gas composition. Its user and customer base includes biogas producers, the chemical industry, and energy and water suppliers. The company has its headquarters in Karlsruhe and a subsidiary in Lübeck. With 30 international distributors, UNION Instruments operates worldwide. The company's core businesses include development and production as well as maintenance, service, and support.

Our service performance



Support

The **UNION-hotline** helps to solve all inquiries and urgent issues fast and easy. Device specific concerns can be solved worldwide within minutes by direct communication via TEAMVIEWER.



Original spare parts

Original spare parts for the majority of UNION's products are in stock directly at site and ready for dispatch within a few hours.



Software

For read-out of measurement and calibration data a device-specific software is available for our clients. In addition to the graphic display of measurement data its export in several database formats is possible.



Training

UNION offers individual in-house training or on-site seminars for installation, use and maintenance of our devices even at the customer's premises. Training is individually adapted to the client's requirements.



Repair service

A global service for inspection, maintenance and repair of our devices and systems is provided directly by UNION and via its distributors.



Certification

Since 20 years we have implemented the ISO9001 system. UNION's products are certified to ATEX and UL/CSA directives accordingly. Industrial safety "**Safety with System**" is part of UNION's company policy.



Engineering

In the last decades UNION compiled a very high level to the state of the art that covers many market segments. So a wide range of possible solution approaches is on hand.



Calibration

As part of maintenance and service UNION provides the validation and re-calibration of measuring devices in conformity with certified custody transfer instruments and / or traceable perpendicular.



Instrumentation Solutions For The Process Industry
Northvale, NJ 07640 Phone (201) 768-7200
Visit us at <http://www.DeltaInstrument.com>